

# **Type Test Procedure For OPGW Cable**

**The type test procedures to be conducted on the OPGW cable are as follows:**

S.No.	TEST NAME	APPLICABLE STANDARD	TEST RESULT (PASS / FAIL)
1	Water Ingress Test	IEEE 1138-2009 Method 6.4.3.5	
2	Seepage of Filling Compound Test	IEEE 1138-2009 Method 6.4.3.6	
3	Short Circuit Test	IEEE 1138-2009 Method 6.4.3.3	
4	Aeolian Vibration Test	IEEE 1138-2009 Method 6.4.3.1	
5	Galloping Test	IEEE 1138-2009 Method 6.4.3.2	
6	Cable Bend Test	IEEE 1138-2009 Method 6.4.2.3	
7	Sheave Test	IEEE 1138-2009 Method 6.4.2.1	
8	Crush Test	IEEE 1138-2009 Method 6.4.2.2	
9	Twist Test	IEEE 1138-2009 Method 6.4.2.4	
10	Creep Test	IEEE 1138-2009 Method 6.4.1.1	
11	Strain Margin Test	IEEE 1138-2009 Method 6.4.1.3	
12	Stress Strain Test	IEEE 1138-2009 Method 6.4.1.2	
13	Temperature Cycling Test	IEEE 1138-2009 Method 6.4.3.7	
14	Corrosion (Salt Spray Test)	IEEE 1138-2009 Method 6.4.3.8	
15	Ultimate Tensile Strength Test	IEEE 1138-2009 Method 6.4.1.4	
16	Lightning Arc Test	IEEE 1138-2009 Method 6.4.3.4	
17	DC Resistance Test	IEEE 1138-2009 Method 6.4.1.5	

**Note:** All Hardware fittings to be used during type test shall be as per approved DRS/ drawings applicable for offered OPGW cable to be type tested.

**Reference docs:**

1. Approved DRS / Drawings of OPGW
2. Approved DRS / Drawings of OPGW fittings
3. Applicable standard. (IEEE 1138-2009)
4. Section -03 – Technical specifications

**TYPE TEST PROCEDURE FOR OPGW CABLE****(1) Test Name: Water Ingress Test****Final Customer: Power Grid Corporation of India Limited, India.****Project Name:****Manufacturer:****Cable Type:****Standard: IEEE 1138-2009 Method 6.4.3.5****CLASSIFICATION:** Operation/environmental/conditional**INTENT**

The intent of the Water Ingress Test is to determine if the quantity of fluid blocking compound in the OPGW cable is sufficient and uniformly distributed to inhibit water from migrating through the optical unit. This test is only applicable for those cable designs that utilize a water-blocking compound inside the optical unit. Water ingress into the optical unit can degrade the performance of the optical fibers.

**OBJECTIVE**

To expose a length of fluid blocked optical unit to a head of water to verify that water does not pass through the unit.

The optical performance of the OPGW cable is not monitored during this test.

**SET-UP**

Water ingress test for OPGW cable that use water-blocking compound is based on the most recent revision of EIA/TIA-455-82-B, except that the retest length, if used, shall be 1 m rather than 3 m.

A 1 m section of OPGW cable shall be prepared for this test. All components of the cable shall be removed from the fluid-blocked optical unit that contains the optical fibers.

The fluid-blocked optical unit shall be positioned horizontally with one end attached to the bottom of a suitable tube containing a column of water that is at least 1 m in height using a watertight fitting. A clear, plastic tube is commonly used for this purpose. No part of the fluid-blocked component shall be above horizontal. The fitting shall not restrict water from entering the optical unit. A collection dish, or equivalent means of detecting water, shall be placed under the open end of the optical unit to collect any water that may pass through it.

Optical measurements are not required for this test.

The optical unit and collection dish shall be visually checked for water. The start and completion times shall be recorded. No electronic measurements are required for this test.

**PROCEDURE**

The reservoir, or tube, shall be filled with water such that the head above the optical unit is least 1.0 m. The water shall be maintained at this level for at least 1 h. During, and at the conclusion of, the 1 h period, the open end of the optical unit shall be visually checked for water.

Acceptance criteria

No water shall leak through the open end of the 1 m sample. If the first sample fails, one additional 1 m sample, taken from a section of OPGW cable immediately adjacent to the first sample, may be tested for acceptance.

OBSERVATIONS, IF ANY:

**TEST RESULT:** The OPGW cable met/not met the acceptance criteria for Water Ingress test.

(TESTED BY)

Sign & Date

(WITNESSED BY)

Sign & Date

**TYPE TEST PROCEDURE FOR OPGW CABLE****(2) Test Name: Seepage of Filling Compound Test****Final Customer: Power Grid Corporation of India Limited, India.****Project Name:****Manufacturer)****Cable Type:****Standard: IEEE 1138-2009 Method 6.4.3.6****Classification :** In-service/environmental/conditional**Intent**

The intent of the Seepage of Flooding Compound Test is to determine if the fluid-blocking compound in the OPGW cable is vulnerable to flowing at elevated temperatures. This test is only applicable for those cable designs that utilize a fluid-blocking compound. The negative impact of the flooding compound seeping is that the compound could accumulate inside the splice box.

**Objective**

- a) To subject the OPGW cable to an elevated temperature that may cause the fluid-blocking compound to drip or otherwise leak from the optical fiber unit.
- b) The optical performance of the OPGW cable is not monitored during this test.

**Set-up**

The test shall be performed in accordance with TIA/EIA-455-81-B, except that an optional preconditioning cycle as described in 5.1.1.2.1 in IEEE Std 1138-1994 [B39] may be used. Five OPGW cable samples, each 30.0 cm  $\pm$  0.5 cm in total length shall be prepared. All metallic strands are cut back 13.0 cm  $\pm$  0.25 cm from one end to expose the fluid-blocked optical unit(s). The sample ends shall not be blocked or sealed. The samples are suspended vertically from a support frame. Small, lightweight collection dishes are placed directly under each sample to collect any fluid-blocking compound that may drip from the optical unit. The samples shall be shielded from any air circulation in the chamber. The temperature in the chamber shall be measured using a thermocouple placed near the support frame close to the samples.

Optical measurements are not required for this test.

**Procedure**

The temperature chamber shall be preheated to at least 65 °C.

The five collection dishes shall be weighed and recorded using a scale having an accuracy of at least  $\pm$ 0.001 g. The support frame, with the covered samples, shall be placed in the chamber. After a 1 h preconditioning period, the samples are removed from the chamber and the dishes weighed and recorded. The dishes are placed under the samples and returned to the chamber. After 23 additional

hours (24 h total), the samples are again removed from the chamber and the dishes weighed and recorded. Changes in weight of  $\pm 0.001$  g are not considered due to leakage of flooding compound.

**Acceptance criteria**

The filling and flooding compound shall not flow (drip or leak) at 65 °C.

**OBSERVATIONS, IF ANY:**

**TEST RESULT:** The OPGW cable met/not met the acceptance criteria for Seepage of Filling Compound test.

**(TESTED BY)**

Sign &amp; Date

**(WITNESSED BY)**

Sign &amp; Date

**TYPE TEST PROCEDURE FOR OPGW CABLE****(3) Test Name: Short Circuit Test****Final Customer: Power Grid Corporation of India Limited, India.****Project Name:****Manufacturer:****Cable Type :****Standard: IEEE 1138-2009 Method 6.4.3.3****Classification :** In-service/electrical/mandatory**Intent**

The intent of the Short-circuit Test is to subject the OPGW cable to short-circuit conditions that represent field conditions. Damage can be inflicted to the cable strands through birdcaging, loss of tensile strength, or melting or softening of non-metallic components because of excessively high temperatures. The optical signals may also be adversely affected by short-circuit conditions.

NOTE—Due to the potential loss of tensile strength of the cable when temperatures exceed 220 °C, a tensile strength test following the Short-circuit Test is recommended on the test sample to verify it meets the vendor's specification for UTS.

**Objective**

- a) To verify the mechanical performance of the OPGW cable when subjected to the specified short circuit conditions.
- b) To verify the optical performance of the OPGW cable when subjected to the specified short-circuit conditions.

**Set-up**

The set-up for the Short-circuit Test is shown in Figure 1.

**Apparatus**

Two OPGW cable samples shall be used for this test. One sample is used to monitor the performance of the optical fibers and to observe any physical damage that might occur during the test. The second sample is used to measure the temperature at several points in the cross-section of the cable. If placed outdoors, the samples shall be positioned such that effects due to wind, solar radiation, etc., are the same on the samples.

The cables shall be electrically connected in series so that they are subjected to the same short-circuit current. Suitable means, such as low level circulating ac current, shall be used to maintain the temperature of the cables as measured by the temperature sample to the manufacturers specified reference temperature for short-circuit capacity of the cable.

**Optical sample**

For optical attenuation measurements, the optical cable sample shall be prepared according to Table 4. The length of cable between the current injection points shall be at least 10 m. The optical fibers shall be terminated beyond each dead-end clamp. A suitable means shall be used to tension the cable from 15% to 20% of the UTS of the OPGW cable when the cable is at the manufacturers specified reference temperature. A suitable device such as a dynamometer or load cell shall be used to measure the tension in this sample.

### **Temperature sample**

The temperature in this sample shall be measured at three locations or more. This is normally achieved using fast-responding thermocouples. However, other techniques that provide reliable and accurate data may be used if available. If thermocouples are used, they shall be spaced approximately 1 m apart, at the midpoint of the sample. They shall be installed in the cable to provide the temperature at the following points in the sample:

- a) Located where the maximum temperature rise is expected. Depending on the design of the OPGW cable, this would normally be aluminum component(s) such as the wires, an aluminum tube, or the slotted central core, if applicable.
- b) Located where the second highest temperature rise is expected. This may involve an aluminum component and a steel component or two steel components.
- c) Located inside the optical unit with the intent of measuring the temperature of the optical fibers.

Thermocouples may be “pinched” between two adjacent components. It is recognized that the thermocouple will be influenced by any components making contact with the junction. The thermocouples shall be isolated from other instrumentation to prevent electrical interference. A suitable means (e.g., turnbuckles, hydraulic cylinder) shall be used to tension this cable but it is not necessary to measure the tension.

### **Instrumentation and data acquisition**

For each short-circuit application, or “pulse,” a suitable data acquisition system shall record the short circuit current, the optical power readings from the optical sample and the thermocouple readings from the temperature sample.

The aluminum, steel, and non-metallic components of the cable will reach their respective maximum temperatures at different times. Typically, the optical unit will take the longest time. For this reason, the data shall be acquired for sufficient time after each pulse in order to record the maximum temperatures of all components. The temperatures in the metallic components may reach their respective maximums in less than 1 s. For this reason, the data sampling rate shall be fast enough to capture these maximums.

### **Procedure**

The cables shall be heated to the manufacturers specified reference temperature as indicated by the highest reading thermocouple in the temperature sample. All thermocouples shall be maintained at a constant temperature. The optical signals shall be stable for at least 15 min before proceeding.

If required, “preliminary” pulses, not to exceed about 50% of the supplier’s specified short current value, may be applied in order for the test lab to establish the proper electrical parameters. Preliminary pulses are not considered part of the “official” test. If necessary, the optical signals shall be allowed to stabilize after the preliminary pulses before proceeding with the official test. Once stable, the difference between the power meters shall be zeroed 5 min before the first official pulse and shall be considered the start of the official test.

The cable shall then be subjected to five official pulses. For the official pulses, the minimum and maximum values for the electrical parameters are shown in Table 1:

**Table 1 —Electrical parameters**

Parameter	Target value
Fault I <sup>2</sup> t	As per approved DRS of OPGW
Fault duration	Same as primary protection breaker operation, if known. Otherwise, maximum 0.5sec (50 Hz)

The cable shall be allowed to cool to the specified reference temperature after each pulse as measured by the highest reading thermocouple. The cable will be held at the reference temperature for at least 5 min between pulses.

For each pulse, the fault current and duration may vary slightly from the target values. The objective is to achieve the I<sup>2</sup>t level for each pulse. To recognize the practical issues of performing this test, the following allowances are made. The average of the five pulses shall exceed the minimum I<sup>2</sup>t level specified by the supplier. However, no single pulse shall be less than 95% of the minimum I<sup>2</sup>t level.

The optical sample shall be visually inspected for bird caging or other damage periodically throughout the test. Because the cable components can be disturbed when the thermocouples are installed, observations made on the temperature sample are not considered official.

After the final pulse, the optical and temperature data shall continue to be acquired for at least 15 min after the thermocouple with the highest reading has returned to the reference temperature. Final optical and temperature readings and observations of the cable shall be taken at this time. This designates the official end of the short-circuit test.

The optical cable sample shall be dissected after the test. Attention shall be paid in particular to the sections of cable closest to the terminating hardware, and at the midpoint of the span. Each separable

component of the cable shall be separated and inspected for excessive wear, discoloration, deformation, or other signs of breakdown.

**Acceptance criteria**

- a) Any cracking or breaking of any component of the optical sample shall constitute failure. This assessment is made with the naked eye.
- b) There shall be no bird-caging of any of the strands of the optical sample. Bird-caging is defined as one or more cable strands that permanently protrude greater than one strand diameter from the normal cable geometry. A strand will be considered to have bird-caged if light can be seen between the protruding strand and the cable. This observation will be made after the cable has cooled to the reference temperature after the last pulse. Temporary bird-caging during the pulses shall not constitute failure.
- c) There shall be no permanent increase in optical attenuation greater than 0.05 dB/fiber at nominally 1550 nm  $\pm$  20 nm for single-mode fibers.
- d) If specified, the maximum temperature of any metallic component shall not exceed the manufacturers' value at any time during the test. Additionally, the temperature of the optical core shall not exceed 180 C at any time during the test. Higher temperatures may be allowed if agreed upon between manufacturer and end user.
- e) Any excessive wear, discoloration of fibers, deformation, or other signs of breakdown shall constitute failure.

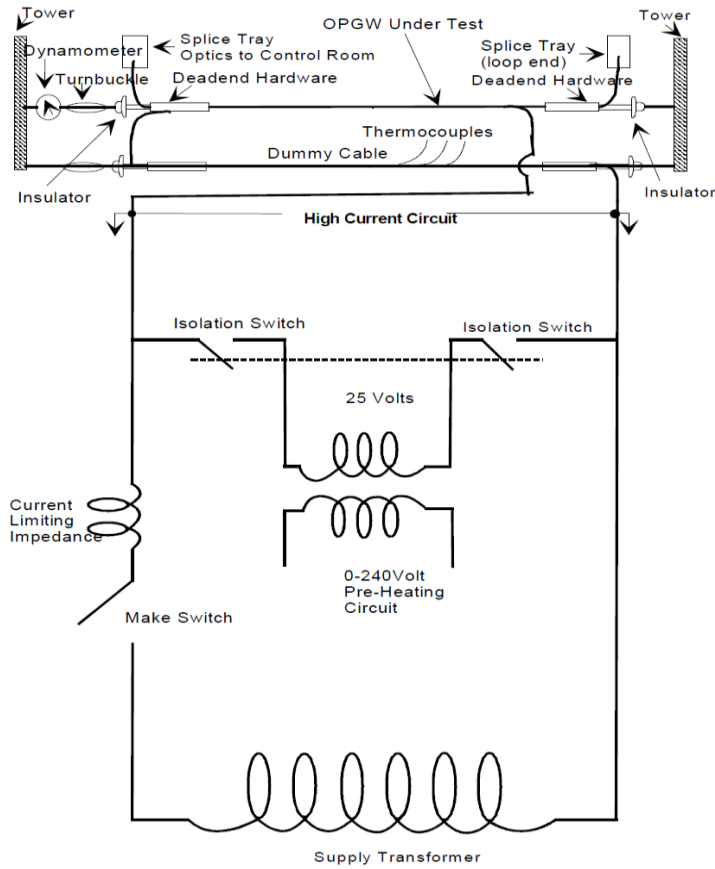

**Figure 1: Test Setup For Short Circuit Test**

**OBSERVATIONS, IF ANY:**

**TEST RESULT:** The OPGW cable met/not met the acceptance criteria for Short Circuit test.

**(TESTED BY)**

Sign & Date

**(WITNESSED BY)**

Sign & Date

**TYPE TEST PROCEDURE FOR OPGW CABLE****(4) Test Name: Aeolian Vibration Test****Final Customer: Power Grid Corporation of India Limited, India.****Project Name:****Manufacturer:****Cable Type:****Standard: IEEE 1138-2009 Method 6.4.3.1****Classification :** In-service/mechanical/mandatory**Intent**

The intent of the Aeolian Vibration Test is to subject the OPGW cable and support hardware to damped aeolian vibrations. This type of conductor vibration is caused by laminar wind as it passes over bare cable and is a common occurrence in the field. Fatigue damage can occur on the metal components of the cable or hardware at attachment locations. The optical signals may also be adversely affected by Aeolian vibration.

**Objective**

- a) To verify the mechanical integrity of the OPGW cable and the supporting hardware when subjected to simulated vibration conditions.
- b) To verify the optical performance of the OPGW cable when subjected to the specified vibration conditions.

**Set-up**

The set-up for the Aeolian Vibration Test is shown in Figure 2.

**Test Apparatus**

The OPGW cable shall be contained between two intermediate abutments. The active span cable length shall be at least 20 m. The passive span cable length shall be approximately half the active span length. Fixed-end abutments shall be used to load and maintain tension in the fiber optic cable.

The dead-end assemblies shall be installed between intermediate abutments. The suspension assembly shall be supported at a height such that the static sag angle of the cable to horizontal shall be  $1.5^\circ \pm 0.5^\circ$  in the active span.

An electronically controlled shaker shall be used to excite the cable in the vertical plane. The shaker armature shall be securely fastened to the cable so that it shall be perpendicular to the cable in the vertical plane. The shaker shall be located in the span to allow a minimum of five vibration loops between the suspension assembly and the shaker.

The cable shall be prepared for attenuation measurements as described in 6.2.

A laser micrometer or other suitable means shall be used to measure the free loop antinode amplitude. The free loop antinode amplitude of the cable shall be measured at the second free loop from the suspension assembly towards the shaker.

A load cell or dynamometer shall be used to measure the cable tension. A thermocouple shall be used to measure the air temperature.

The optical power signals, peak-to-peak free loop amplitude, vibration frequency, number of cycles, cable tension, and air temperature shall be recorded at periodic intervals by a suitable data logging system.

### **Procedure**

The OPGW shall be tensioned to  $25\% \pm 2\%$  of the cable UTS and the exit angles of the cable from the suspension clamp measured. This tension shall be applied using a cantilever weight arm on one of the end abutments or other suitable means.

This tension shall be applied using a cantilever weight arm on one of the end abutments or other suitable means.

The free loop conductor velocity (i.e.,  $f_{y_{max}} = \text{vibration frequency} \times \text{peak-to-peak free loop amplitude}$ ) shall be maintained at an average value of at least 275 mm/s peak for the duration of the test. The vibration frequency shall be approximately equivalent to that produced by a 4.5 m/s wind (i.e.,  $\text{frequency} = 830 \text{ divided by the diameter of the OPGW in mm}$ ). The actual vibration frequency shall produce standing waves and good system stability. The target free loop peak-to-peak antinode amplitude will be approximately onethird the diameter of the cable. This amplitude shall be maintained at this level in the second free loop from the suspension assembly towards the shaker. The frequency and amplitude may vary slightly during the test; however, the average free loop conductor velocity ( $f_{y_{max}}$ ) shall be maintained throughout the test.

The amplitude of the span from the dead end to the shaker and the passive span shall not exceed the amplitude of the span between the shaker and the suspension.

The number of vibration loops shall be counted, and their average loop lengths calculated for each of the three sections of the OPGW. The three sections are (1) between the dead end and shaker, (2) between the shaker and suspension, and (3) in the passive span between the suspension and dead end.

The OPGW shall be subjected to 100 million vibration cycles.

Optical measurements shall be taken for 15 min after the completion of the vibration cycles.

### **Acceptance criteria**

a) Any cracking or breaking of any component of the OPGW cable or the supporting hardware shall constitute failure. This assessment is made with the naked eye.

b) A permanent or temporary increase in optical attenuation greater than 0.2 dB/test fiber km at nominally 1550 nm for single-mode fibers shall constitute failure.

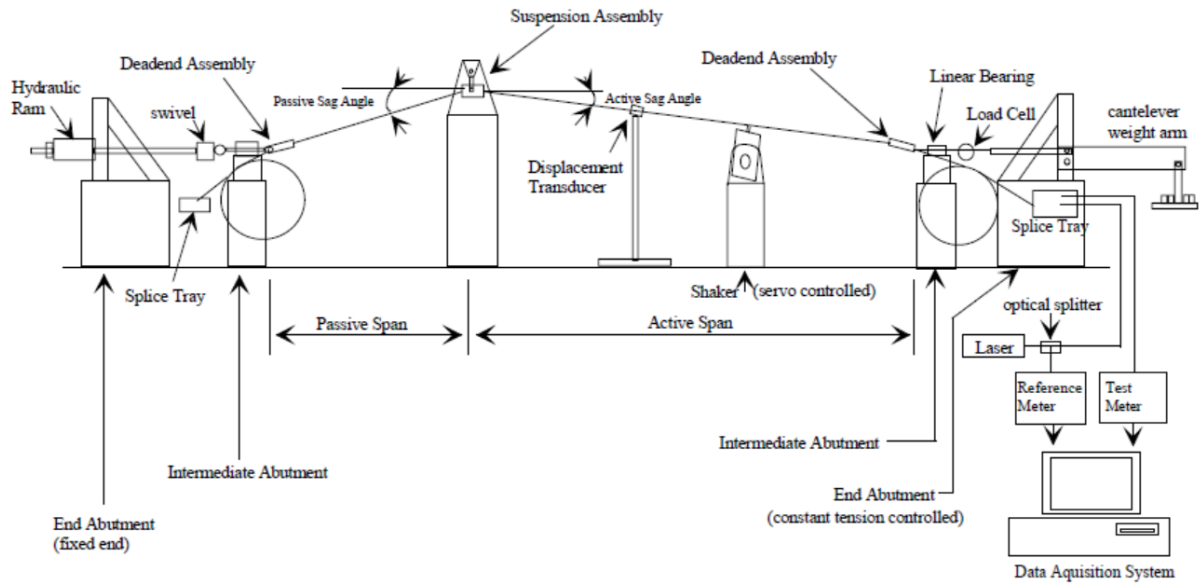

**Figure 2 —General arrangement for Aeolian Vibration Test**

**OBSERVATIONS, IF ANY:**

**TEST RESULT:** The OPGW cable met/not met the acceptance criteria for Aeolian Vibration test.

**(TESTED BY)**

Sign & Date

**(WITNESSED BY)**

Sign & Date

**TYPE TEST PROCEDURE FOR OPGW CABLE****(5) Test Name: Galloping Test****Final Customer: Power Grid Corporation of India Limited, India.****Project Name:****Manufacturer:****Cable Type****Standard: IEEE 1138-2009 Method 6.4.3.2****Classification :** In-service/mechanical/conditional**Intent**

The intent of the Galloping Test is to subject the OPGW cable and support hardware to galloping motions. This type of conductor motion is caused by the wind as it passes over iced cables. This phenomenon can occur in areas that experience icing or wet snow. Fatigue or other damage can occur on the components of the cable, hardware, and/or to the structure. The optical signals may also be adversely affected by galloping.

**Objective**

- a) To verify the mechanical integrity of the OPGW cable and the supporting hardware when subjected to simulated galloping conditions.
- b) To verify the optical performance of the OPGW cable when subjected to the specified galloping conditions.

**Set-up**

The set-up for the Galloping Test is shown in Figure 3.

**Test apparatus**

The test section shall be contained between two intermediate abutments. The active span cable length shall be approximately 20 m and the passive span cable length shall also be approximately 20 m. Fixed-end abutments are used to load and maintain tension in the cable. The initial tension shall be approximately 2% of the cable's UTS. This shall be applied using a cantilever weight arm or other suitable means.

The dead-end assemblies shall be installed between the intermediate abutments. The suspension assembly shall be supported at a height such that the static sag angle of the cable to horizontal shall

be approximately than  $1.5^\circ$  in the active span. A calibrated load cell or dynamometer shall be used to measure the cable tension.

A suitable mechanism (e.g., hydraulically driven, motor-drive) shall be used to oscillate the cable in the vertical plane. The mechanism shall be located in the span and attached to the cable to oscillate the cable in a steady, single-loop gallop motion between the suspension assembly and the shaker.

The free loop antinode amplitude shall be measured in the active span at a point midway between the suspension assembly and the dead end. This shall be achieved by manually observing a graduated scale supported next to the cable.

The cable shall be prepared for attenuation measurements as described in 6.2.

The free loop peak-to-peak antinode amplitude, galloping frequency, optical power signals, tension, and number of cycles shall be recorded at periodic intervals. They may be recorded manually or with a data logging system.

### **Procedure**

Reference optical measurements shall be taken while the cable is at tension and prior to starting the test. The difference between the reference and test signals for the initial measurement provides an initial base reading.

The change in this difference during the test indicates the change in the attenuation of the test fiber.

The cable shall be subjected to 100 000 galloping cycles in the single-loop mode. The frequency shall be adjusted such that the cable exhibits steady, single-loop galloping motions in the active span. The free loop peak-to-peak antinode amplitude shall be maintained at one twenty-fifth of the active span length for the duration of the test. Reasonable movements at both dead end and at the suspension are permitted in order to promote steady galloping motions in the active span. The galloping amplitude in the passive span shall not exceed the amplitude in the active span.

### **Acceptance criteria**

- a) Any cracking or breaking of any component of the OPGW cable or the supporting hardware shall constitute failure. This assessment is made with the naked eye.
- b) A permanent or temporary increase in optical attenuation greater than 0.2 dB/test fiber km at nominally 1550 nm for single-mode fibers shall constitute failure.

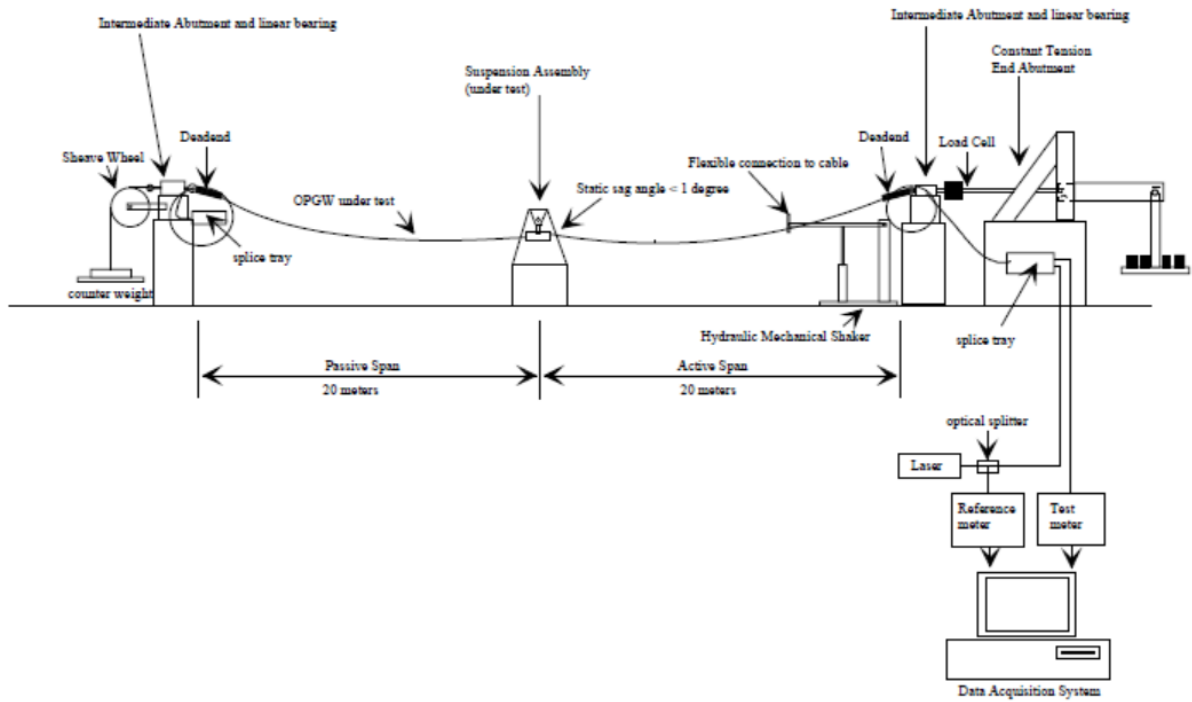

**Figure 3: General Arrangement For Galloping Test**

**OBSERVATIONS, IF ANY:**

**TEST RESULT:** The OPGW cable met/not met the acceptance criteria for Galloping test.

**(TESTED BY)**

Sign & Date

**(WITNESSED BY)**

Sign & Date

## **TYPE TEST PROCEDURE FOR OPGW CABLE**

**(6) Test Name: Cable Bend Test**

**Final Customer: Power Grid Corporation of India Limited, India.**

**Project Name:**

**Manufacturer:**

**Cable Type:**

**Standard : IEEE1138-2009 Method 6.4.2.3**

**Classification :** Installation/mechanical/mandatory

### **Intent**

The intent of the Bend Test is to subject the OPGW cable to a bending action similar to what might be experienced during installation. The cable and/or the optical unit(s) could be damaged and the optical performance could be adversely affected.

### **Objective**

- a) To verify the mechanical integrity of the OPGW cable when subjected to the specified installation conditions.
- b) To verify the optical performance of the OPGW cable when subjected to the specified installation conditions.

### **Set-up**

The preparation of the fibers and number of fibers to be spliced shall be according to 6.2.

### **Procedure**

The minimum bend radius specified by the manufacturer shall be used for the maximum bend radius of the test set-up unless a larger value is agreed to between supplier and purchaser.

The cable sample shall be wrapped two complete times in a close helix around a mandrel with a radius no larger than the minimum bend radius specified by the manufacturer. Sufficient tension shall be applied to ensure that the sample is kept in close contact to the mandrel. The cable shall be held in this position for 1 min.

A reference optical measurement shall be taken prior to bending. Another measurement shall be made after the cable is bent around the mandrel and held stationary. The difference between the two signals for the initial optical measurement provides the test result. The change in this difference during the test would indicate any changes of attenuation in the test fiber. The signals shall be recorded using a digital data logging system.

### **Acceptance criteria**

a) There shall be no cracking or breaking of any component of the OPGW cable constitutes failure.

This assessment is made with the naked eye.

b) There shall be no permanent increase in optical attenuation greater than 0.05 dB/fiber at 1550 nm  $\pm$  20 nm for single-mode fibers.

**OBSERVATIONS, IF ANY:**

**TEST RESULT:** The OPGW cable met/not met the acceptance criteria for Cable Bend test.

**(TESTED BY)**

Sign & Date

**(WITNESSED BY)**

Sign & Date

**TYPE TEST PROCEDURE FOR OPGW CABLE****(7) Test Name: Sheave Test****Final Customer: Power Grid Corporation of India Limited, India.****Project Name:****Manufacturer:****Cable Type:****Standard: IEEE 1138-2009 Method 6.4.2.1****Classification :** Installation/mechanical/mandatory**Intent**

The intent of the Sheave Test is to subject the OPGW cable to a simulated action of being pulled over a number of sheaves during installation. Installation includes stringing and sagging operations. During installation, it is possible the OPGW cable could become excessively deformed. The optical unit(s) could also be damaged and the optic fibers adversely affected.

**Objective**

- a) To verify the mechanical integrity of the OPGW cable when subjected to the specified installation conditions.
- b) To verify the optical performance of the OPGW cable when subjected to the specified installation conditions.

**Set-up**

The general arrangement for the Sheave Test is shown in Figure 4. For optical attenuation measurements, the cable shall be prepared according to 6.2. The length of OPGW cable between loading points of the dead-end assemblies shall be a minimum of 8 m. The sheave shall be rigidly supported such that it can not swing. The diameter of the sheave shall be no greater than 38 to 42 times the OPGW cable diameter unless otherwise specified. The sheave may be grooved or ungrooved and shall be lined. The cable shall be initially tensioned to  $15\% \pm 1\%$  of the cable UTS at a total deflection angle of  $30^\circ \pm 2^\circ$  over the sheave. The method of attachment, while not required to be rigid, shall limit the twisting of the cable occurring near the dead ends. A suitable instrument, such as a dynamometer or load cell, shall be installed to measure the tension in the OPGW cable during the test.

**Procedure**

At least 2.5 m of the cable sample shall be pulled 15 cycles (i.e., 15 times in each direction) over the sheave. Before the first pull, the midpoint and both ends of the 2.5 m length shall be located and marked. A suitable instrument (e.g., caliper, micrometer) shall be used to measure the maximum and minimum diameters at the three locations after tensioning before the first cycle and after the fifteenth cycle. If necessary, the cable tension may be adjusted between cycles to maintain the level at 15%  $\pm$  1% UTS before each cycle.

The cable tension and the optical power meter signals shall be recorded at least two times every cycle using a suitable data logging system.

After the test, the cable section passing over the sheave shall be dissected and all cable components visually

examined for any damage. The maximum and minimum diameters ( $d_{max}$  and  $d_{min}$ , respectively) of the unit(s) containing the fibers shall be measured at the same locations as the cable diameters were measured.

The ovality of the cable and of the optical unit(s) shall be calculated after the test using the following calculation:

$$\text{Ovality} = ((d_{max} - d_{min}) / (d_{max} + d_{min})) * 100\%$$

### **Acceptance criteria**

- a) The ovality of the cable or optical units at the measured locations shall not exceed 10%.
- b) Cracking or breaking of any component of the OPGW cable caused by the test shall constitute failure.

This assessment is made with the naked eye.

- c) A permanent increase in optical attenuation greater than 0.1 dB/test fiber km at 1550 nm  $\pm$  20 nm for single-mode fibers shall constitute failure.

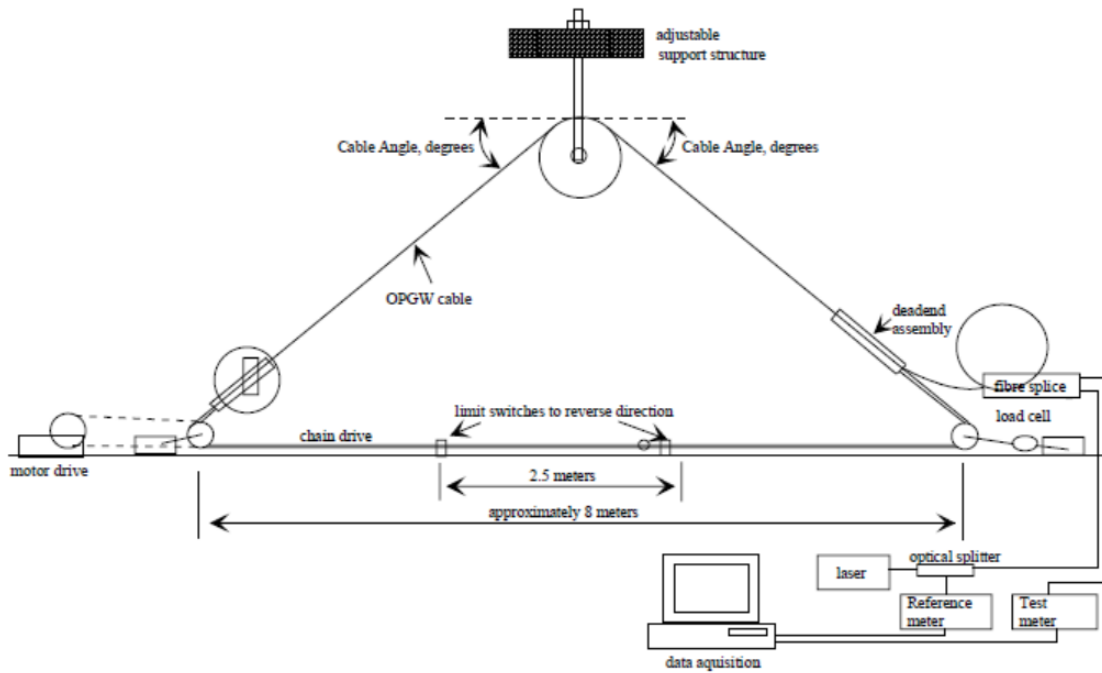

Figure 4: General Arrangement For Sheave Test

**OBSERVATIONS, IF ANY:**

**TEST RESULT:** The OPGW cable met/not met the acceptance criteria for Sheave test.

**(TESTED BY)**

Sign & Date

**(WITNESSED BY)**

Sign & Date

## TYPE TEST PROCEDURE FOR OPGW CABLE

**(8) Test Name: Crush Test**

**Final Customer: Power Grid Corporation of India Limited, India.**

**Project Name:**

**Manufacturer:**

**Cable Type:**

**Standard: IEEE 1138-2009 Method 6.4.2.2**

**Classification :**Installation/mechanical/conditional

### Intent

The intent of the Crush Test is to subject the OPGW cable to simulated crushing or clamping forces that could occur during installation or maintenance. The cable could be crushed to the extent of adversely affecting the optical signals or reducing the tensile strength.

### Objective

- a) To verify the mechanical integrity of the OPGW cable and the supporting hardware when subjected to crush forces.
- b) To verify the optical performance of the OPGW cable when subjected to crush forces.

### Set-up

The set-up for the Crush Test is shown in Figure 5. An untested cable section from the test sample prepared for the Sheave Test may be used for the Crush Test.

The number of fibers to be spliced shall be according to 6.2.

The cable shall be supported between two steel plates that transfer a compressive load uniformly over a 100 mm length of the sample. The edges of the plates shall be slightly rounded. The cable and plates shall be positioned in a suitable test machine. The test shall be carried out in a temperature-controlled laboratory at  $22\text{ }^{\circ}\text{C} \pm 3\text{ }^{\circ}\text{C}$ .

The crush load and the optical power meters shall be monitored and recorded every second by a digital data logging system.

### Procedure

The test shall be performed in accordance with EIA/TIA-455-41-A.

The cable shall be mounted between the plates with minimal load such that the cable is firmly positioned along the length of the steel plates. The load shall be then gradually increased to the value specified by the supplier within 1 min and 2 min and held for 10 min. The test shall be performed at three locations approximately 1 m apart.

The ovality of the cable and of the optical unit(s) shall be calculated after the test using the following calculation:

$$\text{Ovality} = ((d_{\max} - d_{\min}) / (d_{\max} + d_{\min})) * 100\%$$

**Acceptance criteria**

- a) Any ovality of the cable or optical fiber units at the measured locations that exceed 10% shall constitute failure.
- b) Any cracking or breaking of any component of the OPGW cable shall constitute failure.

This assessment is made with the naked eye.

- c) A permanent increase in optical attenuation greater than 0.05 dB/fiber at 1550 nm  $\pm$  20 nm for single-mode fibers shall constitute failure.

The above criteria shall apply to all three test locations.

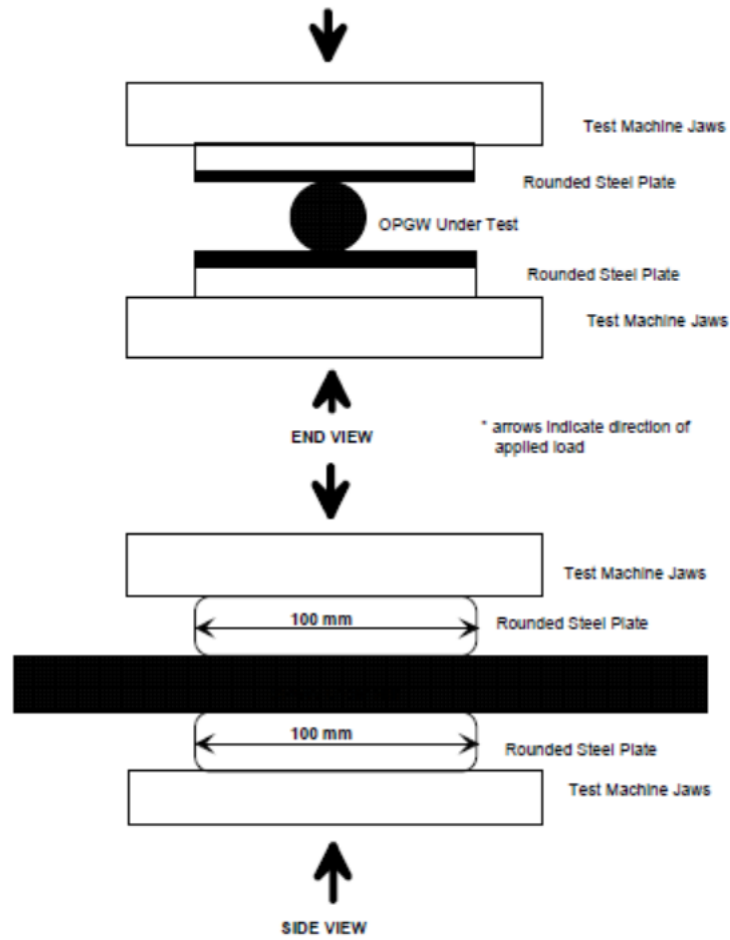

Figure 5: General Arrangement For Crush Test

**OBSERVATIONS, IF ANY:**

**TEST RESULT:** The OPGW cable met/not met the acceptance criteria for Crush test.

**(TESTED BY)**

Sign & Date

**(WITNESSED BY)**

Sign & Date

**TYPE TEST PROCEDURE FOR OPGW CABLE****(9) Test Name: Twist Test****Final Customer: Power Grid Corporation of India Limited, India.****Project Name:****Manufacturer:****Cable Type:****Standard: IEEE 1138-2009 Method 6.4.2.4****Classification :** Installation/mechanical/mandatory**Intent**

The intent of the Twist Test is to subject the OPGW cable to a simulated action of being pulled during installation (i.e., stringing and sagging). During installation, the OPGW cable could become excessively deformed. The optical unit(s) could also be damaged and the optical performance could be adversely affected.

**Objective**

- a) To verify the mechanical integrity of the OPGW cable when subjected to the specified installation conditions.
- b) To verify the optical performance of the OPGW cable when subjected to the specified installation conditions.

**Set-up**

An OPGW cable sample shall be installed in a suitable tension test machine. The length of the cable between the dead-end assemblies shall be at least 10 m. One dead-end assembly shall be attached to the tensioning device through a load cell. The other dead-end assembly shall be attached to the stationery end of the test machine through a swivel. The OPGW cable sample shall be fixed onto itself so as to allow rotational motion without disturbing the optical splice arrangement.

The OPGW cable sample shall be terminated beyond both dead-end assemblies such that the optical fibers could not move relative to the OPGW cable.

The cable and fiber terminations and the method to measure optical attenuation are described in 6.2.

**Procedure**

The cable shall be tensioned to 20% of the cable UTS. The cable sample shall be rotated in the direction of the lay of the strands for two and one-half turns. This number of turns shall be calculated from the test cable length to produce a total twist in the cable of 90° per meter. The cable sample shall be rotated back to the initial position. The cable shall be rotated in the reverse direction to the lay of the strands. The cable sample shall be again reversed in direction to rotate the cable sample to its original position. This constitutes one torsion cycle. This cycle shall be repeated a second time.

The signals from the optical power meters and the cable tension as measured by the load cell shall be monitored continuously and recorded every 10 s using a digital data logging system.

**Acceptance criteria**

a) Any cracking or breaking of any component of the OPGW cable shall constitute failure.

This assessment is made with the naked eye.

b) A permanent increase in optical attenuation greater than 0.10 dB/test fiber km at 1550 nm  $\pm$  20 nm for single-mode fibers shall constitute failure.

**OBSERVATIONS, IF ANY:**

**TEST RESULT:** The OPGW cable met/not met the acceptance criteria for Twist test.

**(TESTED BY)**

Sign & Date

**(WITNESSED BY)**

Sign & Date

**TYPE TEST PROCEDURE FOR OPGW CABLE****(10) Test Name: Creep Test****Final Customer: Power Grid Corporation of India Limited, India.****Project Name:****Manufacturer:****Cable Type:****Standard: IEEE 1138-2009 Method 6.4.1.1****Classification :** Cable characteristic/mechanical/conditional**Intent**

The intent of the Creep Test is to determine the long-term tensile creep characteristics of the OPGW cable.

This information is used in the sag-tension calculations during the design layout of a fiber optic cable system.

**Objective**

- a) To produce the long-term, room temperature tensile creep curve and equation for the OPGW cable.
- b) The optical performance of the OPGW cable is not required to be monitored during this test unless specified by the cable purchaser.

**Set-up**

The test shall be set-up in accordance with IEC 61395 unless otherwise specified by the cable purchaser and where noted in this standard.

The OPGW cable sample shall be terminated such that all the load carrying components of the cable are prevented from moving relative to each other at the loading points. A suggested method is to use epoxyresin grips to encapsulate all components of the cable at the loading points.

The OPGW cable sample shall be installed in a test facility suitable for creep testing. The length of the cable between the loading points of the dead-end assemblies shall be a minimum of 10 m. The cable shall be preloaded to a maximum of 2% of the UTS of the cable. The cable shall not remain at the preload value for more than 5 min. A suitable transducer shall be used to measure the longitudinal cable elongation over a gauge length of at least 8 m. A suitable transducer such as a load cell or dynamometer shall be used to measure the tension in the cable. The cable temperature shall be measured at both ends of the gauge section. The test shall be carried out in a temperature-controlled environment at  $22\text{ }^{\circ}\text{C} \pm 3\text{ }^{\circ}\text{C}$ .

**Procedure**

The test shall be performed in accordance with IEC 61395 unless otherwise specified by the cable purchaser or noted in this standard.

The test tension shall be 25% of the UTS of the cable unless otherwise specified by the cable purchaser.

The cable shall be tensioned at a rate such that the time to reach the test tension  $\pm 2\%$  of this tension is  $5 \text{ min} \pm 10 \text{ s}$ . Final adjustments may be made to achieve the test tension within 10 min of the start of loading. However, the load shall remain within  $\pm 2\%$  of the test tension at all times while any final adjustments are made. Sudden loading or unloading of the cable shall be avoided at all times. The load on the cable shall be maintained at the test tension  $\pm 1\%$  for 1000 h.

The elongation of the cable and applied load shall be monitored and recorded during the test as per IEC 61395 using a suitable data logging system.

#### **Acceptance criteria**

Unless otherwise specified by the cable purchaser, there are no acceptance criteria for this test.

#### **OBSERVATIONS, IF ANY:**

**TEST RESULT:** The OPGW cable met/not met the acceptance criteria for creep test.

**(TESTED BY)**

Sign & Date

**(WITNESSED BY)**

Sign & Date

**TYPE TEST PROCEDURE FOR OPGW CABLE****(11) Test Name: Strain Margin Test****Final Customer: Power Grid Corporation of India Limited, India.****Project Name:****Manufacturer:****Cable Type:****Standard: IEEE 1138-2009 Method 6.4.1.3****Classification :** Cable characteristic/mechanical/mandatory**Intent**

The intent of the Strain Margin Test is to determine the cable tension and strain at which the optical fibers start to elongate. This information is of concern when the cable is exposed to heavy wind and ice conditions.

**Objective**

- a) To determine the cable tension and strain at which the optical fibers begin to elongate.
- b) To verify the optical performance of the OPGW cable during the test.

**Set-up**

The OPGW cable sample shall be terminated such that all of the load carrying components of the cable are prevented from moving relative to each other at the loading points. For optical attenuation measurements, the cable shall be prepared according to 6.2. The number of fibers to be spliced shall be according to 6.2 less the number used for fiber elongation.

For the fiber elongation measurement, at least four fibers shall be spliced together. Fiber elongation shall be measured using suitable optical equipment. If the optical equipment is able to measure fiber strain directly, then a gauge length is not required. If the equipment used measures absolute fiber elongation, such as a high resolution OTDR, then the gauge length shall be taken to be the length of fiber from dead end to dead end, plus half the length of each set of three loops beyond each dead end.

The OPGW cable sample shall be installed in a suitable tensile test machine. The length of the cable between the loading points of the dead-end assemblies shall be a minimum of 10 m. The cable shall be preloaded to a maximum of 2% of the UTS of the cable. It shall be supported over its length such that the cable will not lift by more than 10 mm at the test tension condition. A suitable transducer shall be used to measure the longitudinal cable elongation over a gauge length of at least 8 m. A

suitable transducer such as a load cell or dynamometer shall be used to measure the tension in the cable.

The test shall be carried out in a temperature-controlled environment at  $22\text{ }^{\circ}\text{C} \pm 3\text{ }^{\circ}\text{C}$ .

### Procedure

The cable shall be tensioned at a uniform rate to achieve 100% of the cable UTS in 20 min to 30 min. Readings of the optical attenuation, fiber, and cable elongation shall be taken at periodic intervals while loading the cable. The load shall be continuously increased until the fibers begin to elongate. The data from the instruments shall be recorded simultaneously.

The strain margin is defined as the cable load (or cable strain) at which the fibers have elongated. The methodology to determine onset of fiber strain is shown in IEC 60794-1-2, Method E1, tensile performance.

If agreed between the supplier and the purchaser, the cable may be loaded to failure on completion of the Strain Margin Test to obtain the breaking strength of the cable. If this is done, it is not considered part of the Strain Margin Test and therefore cable strain measurements are not required. If a breaking strength test is performed, the load shall be applied at a rate such that the time to reach the UTS of the cable is at least 5 min. Premature failure of the cable during the breaking strength test does not invalidate the data obtained from the Strain Margin Test.

### Acceptance criteria

Strain margin of the OPGW cable shall be above 47% of its UTS. The cable shall show no permanent increase in optical attenuation greater than 0.20 dB/test fiber km from preload to the maximum rated design tension (MRDT) of the cable at  $1550\text{ nm} \pm 20\text{ nm}$  for single-mode fibers.

### OBSERVATIONS, IF ANY:

**TEST RESULT:** The OPGW cable met/not met the acceptance criteria for Strain Margin test.

**(TESTED BY)**

Sign & Date

**(WITNESSED BY)**

Sign & Date



## **TYPE TEST PROCEDURE FOR OPGW CABLE**

**(12) Test Name: Stress Strain Test**

**Final Customer: Power Grid Corporation of India Limited, India.**

**Project Name:**

**Manufacturer:**

**Cable Type:**

**Standard: IEEE 1138-2009 Method 6.4.1.2**

**Classification :** Cable characteristic/mechanical/mandatory

### **Intent**

The intent of the Stress-Strain Test is to determine the stress-strain characteristics and the final modulus of elasticity (MOE) of the OPGW cable. This information is used in the sag-tension calculations during the design layout of a fiber optic cable system.

### **Objective**

- a) To produce the stress-strain curve and the final MOE for the OPGW cable.
- b) Monitoring the optical performance of the OPGW cable is not required during this test unless specified by the cable purchaser.

### **Set-up**

The test shall be set-up in accordance with IEC 61089 unless otherwise specified by the cable purchaser and where noted in this standard.

The OPGW cable sample shall be terminated such that all the load carrying components of the cable are prevented from moving relative to each other at the loading points. A suggested method is to use epoxyresin grips to encapsulate all components of the cable.

The OPGW cable sample shall be installed in a suitable tensile test machine. The length of the cable between the loading points of the dead-end fittings shall be a minimum of 10 m. The cable shall be preloaded to a maximum of 2% of the UTS of the cable. It shall be supported over its length such that the cable will not lift by more than 10 mm at the maximum tension condition. A suitable transducer shall be used to measure the longitudinal cable elongation over a gauge length of at least 8 m. A suitable transducer such as a load cell or dynamometer shall be used to measure the tension in the cable.

The test shall be carried out in a temperature-controlled environment at  $22\text{ }^{\circ}\text{C} \pm 3\text{ }^{\circ}\text{C}$ .

**Procedure**

The test shall be performed in accordance with IEC 61089 unless otherwise specified by the cable purchaser or noted in this standard.

The cable shall be tensioned according to the loading schedule in the following table. To reduce creep during loading, all loads shall be applied based on the rate to reach 85% of UTS in 2 min. The elongation of the cable and applied load shall be monitored and recorded at appropriate intervals using a suitable data logging system. Load and elongation data shall be recorded a minimum of every 5 min during each hold period and at all preloads. If possible, more frequent readings are preferred.

See Table 2.

**Table 2 —Tension loading schedule**

<b>Step</b>	<b>Load % UTS</b>	<b>Hold time (min)</b>
Preload	2	—
1	30	30
Preload	2	< 2
2	50	60
Preload	2	< 2
3	70	60
Preload	2	< 2
4	85	60
Preload	2	—

The slope of the final unloading curve from 85% UTS is the final MOE of the cable.

If agreed between the supplier and the purchaser, the cable may be loaded to failure on completion of the Stress-Strain Test to obtain the breaking strength of the cable. If this is done, it is not considered part of the Stress-Strain Test and therefore cable strain measurements are not required. If a breaking strength test is performed, the load shall be applied at a rate such that the time to reach the UTS of the cable is at least 5 min. Premature failure of the cable during the breaking strength test does not invalidate the data obtained from the Stress-Strain Test.

**Acceptance criteria**

Unless otherwise specified by the cable purchaser, there are no acceptance criteria for the Stress-Strain Test.

If performed the breaking strength of cable shall meet or exceed 100% of the cable UTS.

**OBSERVATIONS, IF ANY:**

**TEST RESULT:** The OPGW cable met the acceptance criteria for Stress Strain test.

**(TESTED BY)**

Sign & Date

**(WITNESSED BY)**

Sign & Date

**TYPE TEST PROCEDURE FOR OPGW CABLE****(13) Test Name: Temperature Cycling Test****Final Customer: Power Grid Corporation of India Limited, India.****Project Name:****Manufacturer:****Cable Type:****Standard: IEEE 1138-2009 Method 6.4.3.7****Classification :** In-service/environmental/mandatory**Intent**

To subject the OPGW cable to extreme temperatures as may be experienced in the field by the cable.

**Objective**

To verify the optical performance of the OPGW cable when subjected to the specified temperature conditions.

**Set-up**

A sample with a minimum of 500 m of fiber (cabled fiber) shall be placed in a suitable thermal chamber.

For optical attenuation measurements, the optical cable sample shall be prepared according to 6.2.

Two thermocouples shall be placed in the environmental chamber to measure the temperature.

They shall be placed on a 25 cm cable sample located either side of the cable reel.

**Procedure**

The test shall be performed in accordance with TIA/EIA-455-3.

The cable shall be subjected to two thermal cycles. A thermal cycle is based on the chamber temperature starting at

22 °C ± 3 °C, lowering to at least –40 °C and holding for a minimum of 16 h. The temperature shall then be increased to at least 85 °C and held for a minimum of 16 h. To complete the cycle, the temperature shall be returned to 20 °C. All temperature transitions shall be conducted at a rate of 20 °C to 40 °C per hour. The chamber temperature is based on the average of the two thermocouples on the 25 cm cable samples.

At a minimum, the thermocouples and optical data shall be recorded at the beginning and end of the test and at the beginning and end of every hold period.

**Acceptance criteria**

A permanent or temporary increase in optical attenuation greater than 0.2 dB/test fiber km at 1550 nm  $\pm$  20 nm for single-mode fibers shall constitute failure.

**OBSERVATIONS, IF ANY:**

**TEST RESULT:** The OPGW cable met/not met the acceptance criteria for Temperature Cycling test.

**(TESTED BY)**

Sign & Date

**(WITNESSED BY)**

Sign & Date

**TYPE TEST PROCEDURE FOR OPGW CABLE**

**(14) Test Name: Corrosion (Salt Spray Test)**

**Final Customer: Power Grid Corporation of India Limited, India.**

**Project Name:**

**Manufacturer:**

**Cable Type:**

**Standard: IEEE 1138-2009 Method 6.4.3.8**

**Classification :** Storage/in-service, environmental/conditional

**Intent**

To subject the OPGW cable to salt fog corrosion that may be experienced in the field by the cable.

**Objective**

The objective of this test is to determine the effects of a controlled salt atmosphere on the OPGW sample.

**Set-up**

This test is a 1000 h saltbox spray test. Three cable samples of  $75 \text{ cm} \pm 5 \text{ cm}$  shall be cut from the reel of OPGW. Heat shrink tubing or silicone seal shall be placed over both ends of the cable to a distance not to exceed  $7.5 \text{ cm} \pm 0.5 \text{ cm}$  from either end of the cable sample. The purpose of the tubing is to reduce or eliminate the corrosion occurring at the open ends of the test cable.

**Procedure**

The test cables are placed into a standard salt spray-testing box as defined by ISO 9227:2006 [B40] or ASTM B 117 [B3]. The cable samples are to be placed horizontal in the test chamber to simulate a standard horizontally suspended OPGW cable. The test is to run continuously for 1000 h for salt spray testing.

**Acceptance criteria**

At the end of the test, the cables are to be removed and dissected for corrosion damage. The cables have passed the test if:

a) There are no locations where the aluminum-clad steel wires have been pitted so as to expose the underlying steel strength member in any way what so ever.

- b) There are no locations where solid aluminum wires have been point pitted beyond a depth of 10% of the total individual wires diameter at the point of the pit.
- c) There is no damage to the internal fiber containment tubing.
- d) In the case of aluminum coated tubing, there can be no removal of the aluminum coating that exposes the underlying stainless steel tube.
- e) In the case of “other” coated tubing, there can be no removal of the coating that exposes the underlying tubing to the elements.

**OBSERVATIONS, IF ANY:**

**TEST RESULT:** The OPGW cable met/not met the acceptance criteria for Corrosion (Salt Spray test).

**(TESTED BY)**

Sign & Date

**(WITNESSED BY)**

Sign & Date

**TYPE TEST PROCEDURE FOR OPGW CABLE**

**(15) Test Name: Ultimate Tensile Strength Test**

**Final Customer: Power Grid Corporation of India Limited, India.**

**Project Name:**

**Manufacturer:**

**Cable Type:**

**Standard: IEEE 1138-2009 Method 6.4.1.4**

**Classification :** Cable characteristic/mechanical/mandatory

**Intent**

The intent of the Ultimate Tensile Strength Test is to determine the actual breaking strength of the cable.

**Objective**

- a) To verify that the actual (ultimate) tensile strength of the OPGW cable meets or exceeds the UTS of the OPGW cable specified by the supplier.
- b) Monitoring the optical performance of the OPGW cable is not required during this test unless specified by the cable purchaser.

**Set-up**

The OPGW cable sample shall be installed in a suitable tensile test machine. The length of the cable between the loading points of the dead-end assemblies shall be a minimum of 10 m. A suitable transducer such as a load cell or dynamometer shall be used to measure the tension in the cable.

**Procedure**

The load shall be applied at a uniform rate such that the time to reach the UTS of the cable is at least 5 min. The ultimate tensile strength of the cable shall be defined as the maximum load the cable can withstand before failure. Individual strand failures do not necessarily constitute cable failure. However, no outer layer strands shall fail below 75% of the cable UTS. This is to ensure that the outer strands will not unravel below the maximum design loading conditions.

This test may be performed separately or on the same cable sample as the Stress-Strain Test or the Strain Margin Test. In this case, the Ultimate Tensile Strength Test would be performed immediately following the Stress-Strain Test or the Strain Margin Test.

**Acceptance criteria**

The ultimate tensile strength of the OPGW cable shall meet or exceed 100% of the UTS of the cable. In addition, any outer layer strand failing below 75% of the cable UTS shall constitute failure. If the maximum load does not meet 100% of the UTS of the cable, the test shall be repeated if the following occurs:

- a) The break occurs beneath or within 50 mm (2 in) of a dead-end fitting.
- b) The OPGW cable slips in a dead-end fitting.

**OBSERVATIONS, IF ANY:**

**TEST RESULT:** The OPGW cable met/not met the acceptance criteria for Ultimate Tensile Strength Test .

**(TESTED BY)**

Sign & Date

**(WITNESSED BY)**

Sign & Date

**TYPE TEST PROCEDURE FOR OPGW CABLE**

**(16) Test Name: Lightning Arc Test**

**Final Customer: Power Grid Corporation of India Limited, India.**

**Project Name:**

**Manufacturer:**

**Cable Type:**

**Standard: IEEE 1138- 2009 Method 6.4.3.4**

**Classification :** In-service/electrical/mandatory

**Intent**

The intent of the Lightning Arc Test is to subject the OPGW cable to lightning conditions that represent field conditions. Damage can be inflicted to the cable strands through loss of tensile strength as a result of melting or softening of strands because of extremely high temperatures. The optical signals may also be adversely affected by lightning conditions.

**Objective**

- a) To verify the mechanical performance of the OPGW cable when subjected to the specified lightning conditions.
- b) To verify the optical performance of the OPGW cable when subjected to the specified lightning conditions.

**Set-up**

The test shall be set-up in accordance with IEC 60794–1-2, Method H2, unless otherwise specified by the cable purchaser and where noted in this Standard.

**Test apparatus**

An OPGW sample shall be installed between two fixed abutments. The length of the cable between the load points of the dead-end assembly shall be greater than 10 m. A load cell or dynamometer shall measure the tension in the cable.

**Optical network**

For optical attenuation measurements, the sample shall be prepared according to 6.2. The optical attenuation shall be monitored and recorded by a digital data logging system at a suitable sampling rate. The tension may be recorded manually.

**Procedure**

The test shall be performed in accordance with IEC 60794-1-2, Method H2, unless otherwise specified by the cable purchaser and where noted in this standard.

Five sections of the cable sample shall be tested separately according to Table 3. The class of the OPGW cable shall be agreed between the purchaser and the manufacturer.

<b>Table 3 – Test parameters</b>	
	Class 1
Current (A)	200
Duration (S)	0.5
Charge transfer (C)	100

Each section shall be tensioned to 15% to 20% of the cable UTS. An arc current with negative polarity on the electrode shall be applied to the cable through a 5 cm ± 1 cm long thin filament. A thin filament may be used to initiate the arc to the cable. The charge transference to the cable shall be as specified by the supplier. The tolerance on the charge transference is ±10%. A charge exceeding 110% of the target value may also be acceptable.

After the Lightning Arc Test, the sections of the cable sample shall be tension tested to determine the remaining strength. If there are broken wires, the numbers and types (aluminum, ACS) of the broken wires shall be reported. For information purposes, the cable and its components shall be inspected and material changes shall be documented.

**Acceptance criteria**

- a) There shall be no permanent increase in optical attenuation greater than 0.05 dB/fiber at nominally 1550 nm ± 20 nm for single-mode fibers.
- b) The minimum remaining strength of any of the tested cable sections shall be greater than 75% of the cable UTS.

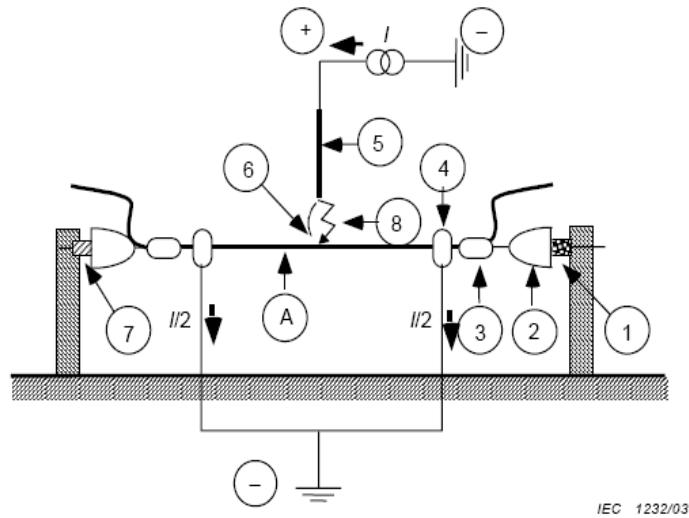

- |   |                                       |   |   |
|---|---------------------------------------|---|---|
| 1 | Turnbuckle                            | 5 | Electrode with plane surface preferring Wolfram – Copper  |
| 2 | Insulator                             | 6 | Metal fuse for ignition                                   |
| 3 | Anchoring clamps                      | 7 | Tension meter   |
| 4 | Symmetric earthing connectors         | 8 | Gap between electrode and cable surface $\leq 6\text{cm}$ |
| A | Test sample (inc OPAC messenger wire) |   |   |

**Figure 6: Test Setup For Lightning Arc Test**

**OBSERVATIONS, IF ANY:**

**TEST RESULT:** The OPGW cable met/not met the acceptance criteria for Lightning Arc test.

**(TESTED BY)**

Sign & Date

**(WITNESSED BY)**

Sign & Date

**TYPE TEST PROCEDURE FOR OPGW CABLE**

**(17) Test Name: DC Resistance Test**

**Final Customer: Power Grid Corporation of India Limited, India.**

**Project Name:**

**Manufacturer:**

**Cable Type:**

**Standard: IEEE 1138-2009 Method 6.4.1.5**

**Classification :** Cable characteristic/electrical/mandatory

**Intent**

The intent of the DC Resistance Test is to determine the actual dc resistance of the cable.

**Objective**

a) To verify that the actual dc resistance of the OPGW cable does not exceed the dc resistance stated by the supplier.

**Set-up and procedure**

Copper connectors shall be crimped on each end of a 5 m cable sample. Alligator-type clips shall be used to connect a calibrated current source of 10 A to the cable. A bar with a calibrated length of about 1 m with sharp knife edges shall be used to obtain a precise gauge length.

Optical measurements are not required for this test.

The potential drop between the knife edges shall be measured by a micro-ohmmeter and displayed directly as micro-ohms. Resistance measurements shall be taken five times. The dc resistance per meter of the cable shall be calculated by averaging the five individual measurements and dividing by the gauge length. To minimize error due to heating, the current shall be injected through the cable for only a few seconds to obtain a reading. The temperature at the time of testing shall be recorded. If the temperature of the cable at the time of measurement is lower than that specified by the cable manufacturer, then the resistance measurements shall be corrected to the specified temperature.

**Acceptance criteria**

The actual dc resistance of the OPGW cable shall not exceed the dc resistance stated by the manufacturer at the specified temperature.

**OBSERVATIONS, IF ANY:**

**TEST RESULT:** The OPGW cable met/not met the acceptance criteria for DC Resistance test.

**(TESTED BY)**

Sign & Date

**(WITNESSED BY)**

Sign & Date

**Space for Observations**

**IEEE-1138:2009 Clause 6.2**

**Procedure for optical measurements and fiber preparation:**

To increase the sensitivity to changes in attenuation, a number of fibers in each test sample are spliced together, or concatenated, to form one long, continuous optical path. The minimum number of fibers to be spliced and monitored for applicable tests is shown in Table-1. Whenever possible, an equal number of fibers shall be selected from each optical unit.

**Table-4 Minimum Fibers for Tests**

Cable fiber Count	Minimum number of fibers to be spliced and monitored
1 to 24	All
25 to 48	24
49 to 96	36
97 to 192	48
193 to 384	60
385 to 768	72

A laser source with the appropriate wavelength is injected to an optical splitter. The splitter divides the source signal into two signals with nominally equal optical power. During the test, the optical measuring system (source, splitter, and receiver) shall remain stable. One of the split signals is sent directly to an optical power meter and serves as the reference signal. The other split signal is spliced into one of the free ends of the concatenated test fibers. A second power meter is connected to the returning end of the test fibers. This measurement is the test signal. During the tests, the readings from the reference and test optical power meters are monitored and recorded periodically in a suitable manner for future analysis. Any changes from the initial difference between the reference and test signals indicate a change in the attenuation in the fibers due to the test. A net increase in attenuation indicates a loss in the optical signal strength. A net decrease in attenuation indicates a gain in the signal strength.

For tests where the OPGW is subjected to tension, the samples are terminated in a manner such that the optical fibers at both ends of the sample cannot move relative to the OPGW cable. Although other arrangements may be used, an example of an arrangement for preparing loops between the test sample and the fiber splice tray is shown in Figure 1. Three loops of cable with a diameter of 1 m are formed and secured as close as possible to the dead-end tension clamps. Another three loops of the fiber optic unit only are formed just in front of the splice tray. This configuration will ensure that

all metallic, non-metallic and fiber components are prevented from relative movement during the test.

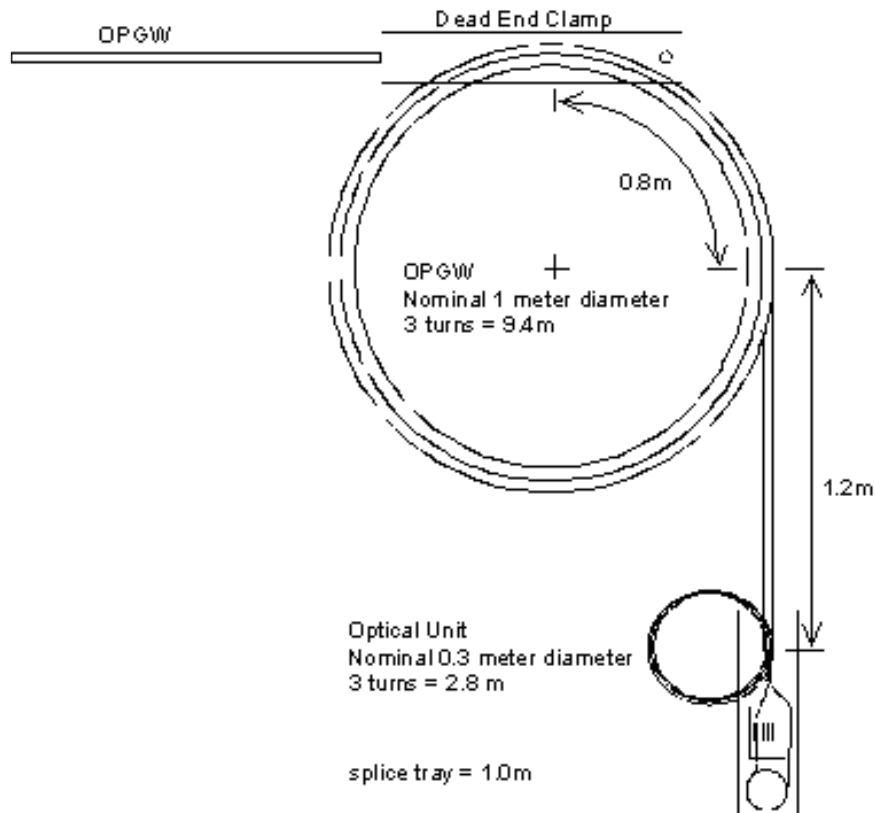

Total length:  $9.4 + 0.8 + 1.2 + 2.8 + 1.0 = 15.2\text{m}$

**Figure 7 : Test Sample Termination Arrangement**